

Quintix[®] Pro



Benefits

- Enhance the user experience with new premium features
- Offering a wide range of use in different environments and applications
- Energy efficiency, reduced carbon footprint, and sustainability, minimizing environmental impact from the manufacturing plant to the bench

Product Information

It's easy to overlook the standard lab balance. To expect the ordinary. Until something new comes along that redefines what a standard balance can be.

Quintix[®] Pro Laboratory Balances deliver the performance you need, with added premium features that raise the bar in usability, flexibility, and eco-conscience design.

Technical Specifications

General Technical Data

Ambient Conditions		Value
Installation site	For indoor use only, max. height above sea level	3000 m
Temperature	Environment (metrological data)*	+10 - +30° C
	Environment	+5 - +40° C
	Storage and transport	-20 - +60° C
Relative humidity**	At temperatures up to 31° C, non-condensing, then linear decrease from max. 80% at 31° C to max. 50% at 40° C	80%
No heat from heating systems or direct sunlight		
No electromagnetic fields		
Power Supply Device		Value
Input voltage		15 V _{DC} (±10%)
Power consumption, max		4 W
Only by Sartorius power supply unit YEPS01-15V0W with interchangeable country-specific plug-in AC adaptors		
Power Supply Unit		Value
Type: Sartorius power supply unit YEPS01-15V0W		
Primary	Voltage	100 - 240 V _{AC} (±10%)
	Frequency	50 - 60 Hz
	Current consumption, maximum	0.2 A
Secondary	Voltage	15 V _{DC} (±5%)
	Current, maximum	0.53 A
Short-circuit protection		Electronic
Protection class according to IEC 60950-1		II
Pollution level according to IEC 61010-1		2
Overvoltage category according to IEC 60664-1		II
Other data: See label on the power supply unit		
Electromagnetic Compatibility		
Interference resistance: Suitable for use in industrial areas		
Transient emissions	Class B Suitable for use in residential areas and areas that are connected to a low voltage network that also supplies residential buildings	
Materials		
Housing	Polybutylene terephthalate (PBT)	
Control module	Glass	
Draft shield	Glass polybutylene terephthalate (PBT)	
Weighing pan	Stainless steel	
Warm-up Time		Value
Device, approx		2 hr

* For conformity-assessed (verified) balances in accordance with EU requirements, refer to the information on the balance.

** For conformity-assessed (verified) balances in accordance with EU requirements, the legal regulations apply.

Interfaces

Specifications of the RS232 Interface

Type of interface	Serial interface
Interface operation	Full duplex
Level	RS232
Connection	D-sub connector, 9-pin
Maximum cable length	10 m

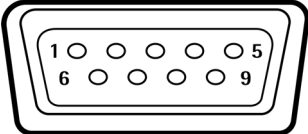
Pin assignment		Pin 1: Not assigned Pin 2: Data output (TxD) Pin 3: Data input (RxD) Pin 4: Not assigned Pin 5: Internal ground	Pin 6: Not assigned Pin 7: Clear to Send (CTS) Pin 8: Request to Send (RTS) Pin 9: Not assigned
----------------	---	---	--

Specifications for the USB-C Interface (back)

Communication	USB UTL
Connectable devices	Sartorius printers, Sartorius second display, FTDI cable or USB memory stick

Specifications for the PC-USB Interface (back)

Communication	USB Device
Connectable devices	PC

Specifications for the USB-C Interface (front)

Communication	USB UTL
Connectable devices	Sartorius printers, Sartorius second display, FTDI cable or USB memory stick

Calibration

- Internal calibration isoCAL
 - Internal calibration
 - 3-point calibration
 - External calibration
-

Selectable Weight Units*

Gram, kilogram, carat, pound, ounce, troy ounce, Hong Kong tael, Singapore tael, Taiwan tael, grain, pennyweights, milligram, parts per pound, China tael, mommes, Austrian carat, tola, baht, mesghal and Newton

Display

Intuitive graphic touch technology

Built-in Applications

- Weighing | Dosing
 - Mass unit conversion
 - Counting
 - Percentage weighing
 - Calculation
 - Mixing
 - Components
 - Density determination
 - Statistics
 - Checkweighing
 - Animal weighing
 - Peakhold
 - Pipette smart check
 - Differential weighing
 - Underfloor weighing
-

Languages

Chinese, Czech, Dutch, English, French, German, Hungarian, Italian, Japanese, Korean, Polish, Portuguese, Russian, Spanish, Turkish

Protection

- Chemical resistant housing parts
 - Glass parts of the draft shield are coated to reduce electrostatic influences
 - Display foil (available as accessory)
 - Dust cover for balances (also available as accessory)
 - In-use-cover for housing (also available as accessory)
 - In-use-cover for weighing pan (available as accessory)
-

Anti-theft Lock

Kensington lock and lockdown capability for cable or chain

* The availability of units depends on national legislation and is therefore country-specific.

Model specific data

For models with internal adjustment feature

Model QTX	Unit	324lxy-1z ¹	224lxy-1z ¹	124lxy-1z ¹
Readability Scale interval (d)	mg	0.1	0.1	0.1
Maximum capacity (Max)	g	320	220	120
Weighing system		EMC	EMC	EMC
Repeatability				
At 5% load, typical value	± mg	0.08	0.08	0.08
At approx. maximum load, typical value	± mg	0.1	0.1	0.1
Linearity deviation				
Limits	± mg	0.2	0.2	0.2
Typical value	± mg	0.06	0.06	0.06
Eccentricity deviation (Deviation when load is off-center, positions according to OIML R76)				
Test weight	g	200	100	50
Tolerance	± mg	0.4	0.4	0.4
Typical value	± mg	0.2	0.12	0.1
Sensitivity drift between +10° C and +30° C	± ppm/K	1	1	1
Tare maximum capacity (subtractive)		<100% of maximum capacity		
isoCAL:				
Temperature change	K	1.5	1.5	1.5
Time interval	h	4	4	4
For models with approval:				
Accuracy class		I	I	I
Type		BC-QA	BC-QB	BC-QB
Verification scale interval (e)	mg	1	1	1
Minimum load (Min)	mg	10	10	10
Minimum initial weighing according to USP (United States Pharmacopeia), Chap. 41				
Optimum minimum initial weighing	g	0.082	0.082	0.082
Typical minimum initial weighing	g	0.16	0.16	0.16
Typical measurement time	s	≤2.0	≤2.0	≤2.0
Typical stabilization time	s	≤1.5	≤1.5	≤1.5
Recommended calibration weight				
External calibrated test weight	g	200	200	100
Accuracy class in accordance with OIML R111-1		E2	E2	E2
Weighing pan size	mm	Ø 90	Ø 90	Ø 90
Weighing chamber height*	mm	240	240	240
Dimension (W x D x H)	mm	220 x 377 x 346	220 x 377 x 346	220 x 377 x 346
Net weight, approx.	kg	6.70	6.70	6.70
Gross weight, approx.	kg	8.65	8.65	8.65

* upper edge of the weighing pan to the lower edge of the upper draft shield panel

¹ Levelling, x =
 x = R : Real-time level support
 x = M : Motorized, automatic level feet

¹ Draft shield, y =
 y = U : Manual, glass
 y = O : No draft shield

¹ Country-specific marking in model, z =
 z = S : Standard balances without country-specific additions
 z = SAR : Standard balances with country-specific additions for Argentina
 z = SJP : Standard balances with country-specific additions for Japan
 z = SKR : Standard balances with country-specific additions for South Korea
 z = CEU : Conformity-assessed balances with EU type examination certificate without country-specific additions
 z = CFR : Conformity-assessed balances with EU type examination certificate only for France

z = NUS : Balances with approval for Canada and USA
 z = OBR : Balances with approval for Brazil
 z = OCN : Balances with approval for China
 z = OIN : Balances with approval for India
 z = OJP : Balances with approval for Japan
 z = ORU : Balances with approval for Russia

1503lxy-1z ¹	1203lxy-1z ¹	623lxy-1z ¹	423lxy-1z ¹	323lxy-1z ¹
1	1	1	1	1
1.500	1,200	620	420	320
EMC	EMC	EMC	EMC	EMC
0.5	0.5	0.5	0.5	0.5
1	1	1	1	1
2	2	2	2	2
0.6	0.6	0.6	0.6	0.6
500	500	200	200	200
2	2	2	2	2
1	1	1	1	1
1,5	1,5	2	2	2
<100% of maximum capacity				
1.5	1.5	2	2	2
4	4	6	6	6
I	I	II	II	II
BC-QC	BC-QC	BC-QD	BC-QD	BC-QD
10	10	10	10	10
100	100	20	20	20
0.82	0.82	0.82	0.82	0.82
1	1	1	1	1
≤1.5	≤1.5	≤1.5	≤1.5	≤1.5
≤1.0	≤1.0	≤1.0	≤1.0	≤1.0
1,000	1,000	500	200	200
E2	E2	F1	F1	F1
Ø 120	Ø 120	Ø 120	Ø 120	Ø 120
240	240	240	240	240
220×377×346	220×377×346	220×377×346	220×377×346	220×377×346
8.10	8.10	6.70	6.70	6.70
10.03	10.03	8.65	8.65	8.65

Model QTX	Unit	6202lxy-1z ¹	4202lxy-1z ¹	3202lxy-1z ¹	2202lxy-1z ¹
Readability Scale interval (d)	mg	10	10	10	10
Maximum capacity (Max)	g	6,200	4,200	3,200	2,200
Weighing system		EMC	EMC	EMC	EMC
Repeatability					
At 5% load, typical value	± mg	5	5	5	5
At approx. maximum load, typical value	± mg	10	10	10	10
Linearity deviation					
Limits	± mg	20	20	20	20
Typical value	± mg	6	6	6	6
Eccentricity deviation (Deviation when load is off-center, positions according to OIML R76)					
Test weight	g	2,000	2,000	2,000	1,000
Tolerance	± mg	20	20	20	20
Typical value	± mg	10	10	10	10
Sensitivity drift between +10° C and +30° C	± ppm/K	2	2	2	2
Tare maximum capacity (subtractive)		<100% of maximum capacity			
isoCAL:					
Temperature change	K	2	2	2	2
Time interval	h	6	6	6	6
For models with approval:					
Accuracy class		II	II	II	II
Type		BC-QE	BC-QE	BC-QE	BC-QE
Verification scale interval (e)	mg	100	100	100	100
Minimum load (Min)	mg	500	500	500	500
Minimum initial weighing according to USP (United States Pharmacopeia), Chap. 41					
Optimum minimum initial weighing	g	8.2	8.2	8.2	8.2
Typical minimum initial weighing	g	10	10	10	10
Typical measurement time	s	≤1.0	≤1.0	≤1.0	≤1.0
Typical stabilization time	s	≤0.9	≤0.9	≤0.9	≤0.9
Recommended calibration weight					
External calibrated test weight	g	5,000	2,000	2,000	2,000
Accuracy class in accordance with OIML R111-1		F1	F1	F1	F1
Weighing pan size	mm	182 × 182	182 × 182	182 × 182	182 × 182
Weighing chamber height*	mm	-	-	-	-
Dimension (W x D x H)	mm	215 × 377 × 95	215 × 377 × 95	215 × 377 × 95	215 × 377 × 95
Net weight, approx.	kg	6.20	6.20	6.20	6.20
Gross weight, approx.	kg	8.40	8.40	8.40	8.40

* upper edge of the weighing pan to the lower edge of the upper draft shield panel

¹ Levelling, x =
x = R : Real-time level support
x = M : Motorized, automatic level feet

¹ Draft shield, y =
y = U : Manual, glass
y = O : No draft shield

¹ Country-specific marking in model, z =
z = S : Standard balances without country-specific additions
z = SAR : Standard balances with country-specific additions for Argentina
z = SJP : Standard balances with country-specific additions for Japan
z = SKR : Standard balances with country-specific additions for South Korea
z = CEU : Conformity-assessed balances with EU type examination certificate without country-specific additions
z = CFR : Conformity-assessed balances with EU type examination certificate only for France

z = NUS : Balances with approval for Canada and USA
z = OBR : Balances with approval for Brazil
z = OCN : Balances with approval for China
z = OIN : Balances with approval for India
z = OJP : Balances with approval for Japan
z = ORU : Balances with approval for Russia

1202lxy-1z ¹	12201lxy-1z ¹	10201lxy-1z ¹	8201lxy-1z ¹	6201lxy-1z ¹	3201lxy-1z ¹
10	100	100	100	100	100
1,200	12,200	10,200	8,200	6,200	3,200
EMC	EMC	EMC	EMC	EMC	EMC
5	50	50	50	50	50
10	100	100	100	50	50
20	100	100	100	100	100
6	60	60	60	60	60
500	5,000	5,000	5,000	2,000	2,000
20	200	200	200	200	200
10	100	100	100	100	100
2	4	4	4	2	2
<100% of maximum capacity					
2	2	2	2	2	2
6	6	6	6	6	6
II	II	II	II	II	II
BC-QE	BC-QG	BC-QG	BC-QG	BC-QG	BC-QE
100	1,000	1,000	1,000	100	100
500	5,000	5,000	5,000	5,000	5,000
8.2	82	82	82	82	82
10	100	100	100	100	100
≤1.0	≤1.0	≤1.0	≤1.0	≤1.0	≤1.0
≤0.9	≤0.9	≤0.9	≤0.9	≤0.9	≤0.9
1,000	10,000	10,000	5,000	5,000	2,000
F1	F2	F2	F2	F2	F2
182×182	182×182	182×182	182×182	182×182	182×182
-	-	-	-	-	-
215×377×95	215×377×95	215×377×95	215×377×95	215×377×95	215×377×95
6.20	6.20	6.20	6.20	6.20	6.20
8.40	8.40	8.40	8.40	8.40	8.40

Technical Drawings

Models with a readability of 0.1 mg
All dimensions are given in millimeters

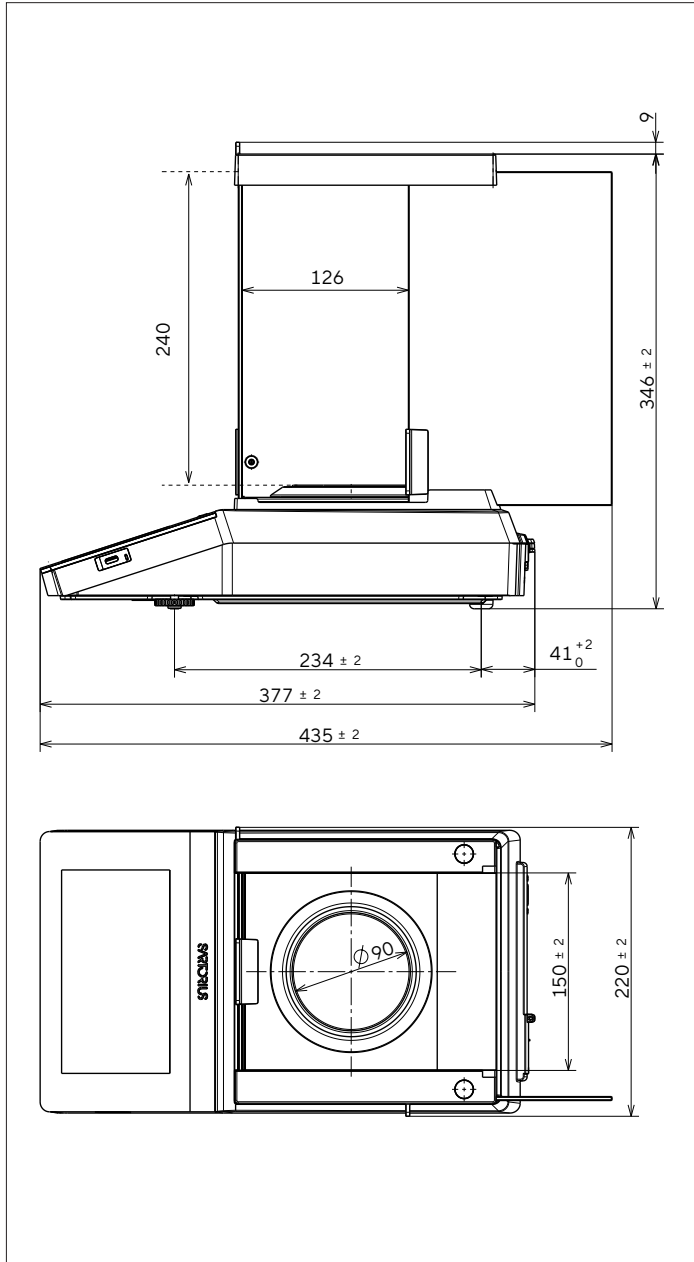

Models with a readability of 1 mg
All dimensions are given in millimeters

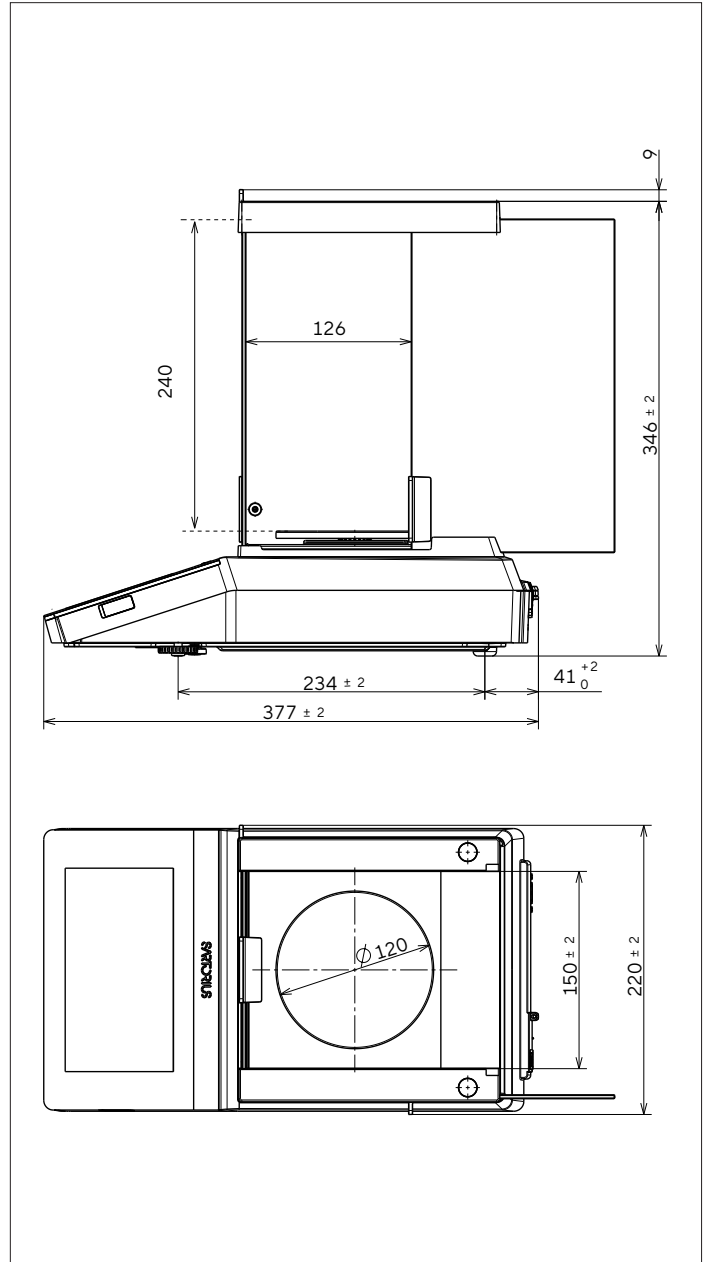

Models with a readability of ≥ 10 mg
All dimensions are given in millimeters

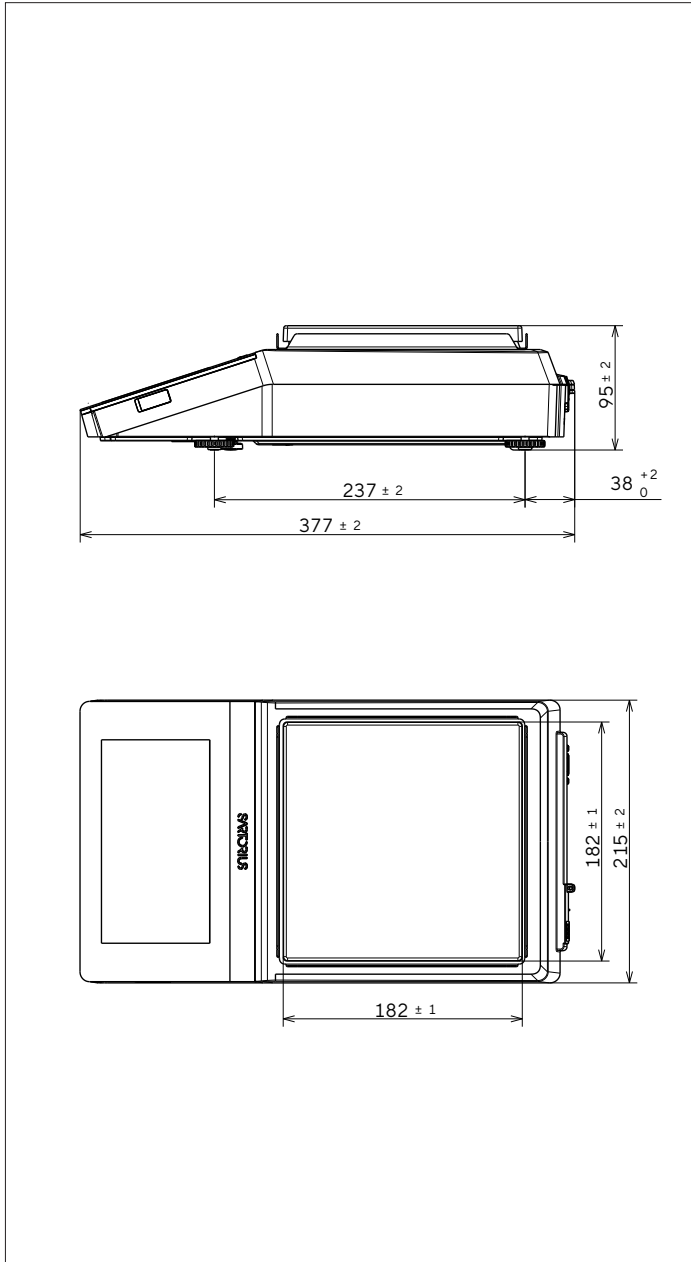

Accessories

These tables contain an excerpt of the accessories that can be ordered. For information on other products, contact Sartorius.

Balance Accessories

Item	Quantity	Order number
Display protection film (set of 5)	1	YDC40
Dust cover for balances with an analytical draft shield	1	6960SE06
Dust cover for balances with rectangular weighing pan	1	6960SE07
In-use cover for balances with an analytical draft shield (1 piece)	1	6960SE08
In-use cover for balances with an analytical draft shield (set of 5)	1	6960SE08-5
In-use cover for balances with rectangular weighing pan (1 piece)	1	6960SE09
In-use cover for balances with rectangular weighing pan (set of 5)	1	6960SE09-5
Set protection cover for 90 mm weighing pan and draft shield base plate (set of 5)	1	YIC02-A
Set protection cover for 120 mm weighing pan and draft shield base plate (set of 5)	1	YIC02-M
Set protection cover for 182 × 182 mm weighing pan (set of 5)	1	YIC02-P
Round glass draft shield for balances with a readability of 1 mg	1	YDS02QTX
Density determination set		
for solids and liquids for balances with a readability of 0.1 mg 1 mg	1	YDK03
for solids and liquids for balances with a readability of ≥10 mg	1	YDK04QTX
Demo transportation case	1	YDB01QTX
“Kensington Lock” anti-theft device	1	YKL01
Pedal button foot switch	1	YFS04
Second display remote display	1	YSD01
Converter cable 5 VDC > 15 VDC	1	YCC-5V-15V
Weighing table		
Made from wood with natural stone	1	YWT09
Made from natural stone, with vibration dampening	1	YWT03
Wall console made from natural stone	1	YWT04

Printer and Accessories for Data Communication

Item	Quantity	Order number
Thermal transfer printer (USB-B, RS232)	1	YDP30
Thermal printer (USB-B)	1	YDP40
Dot matrix printer (USB-B, RS232)	1	YDP50
Dot matrix printer (RS232)*	1	YDP20-0CE
Data cable USB-C > USB-B (>YDP30, YDP40, YDP50), 1.5 m	1	YCC-USB-C-B
Data cable USB-C > USB-A (>PC), 1.5 m	1	YCC-USB-C-A
Data cable RS232 (9-pin) > USB-A (>PC), 1.5 m	1	YCC-D09M-USB-A
Data cable RS232 (9-pin) male > RS232 (9-pin) male (>YDP30), 1.5 m	1	YCC-D09MM
Data cable RS232 (9-pin) male > RS232 (9-pin) female (>YDP20-0CE, YSD01), 1.5 m	1	YCC-D09MF
Y-adaptor RS232 (9-pin) male > 2× RS232 (9-pin) female, 0.15 m	1	YCC-D09M-2D09F

*additional power supply e.g. YEPS01-PS4 or YEPS01-PS5 is required

External Calibration and Adjustment Weights

QTX model	Weight	Accuracy class	Order number
324 224	200 g	E2	YCW522-AC-02
124	100 g	E2	YCW512-AC-02
1503 1203	1,000 g	E2	YCW612-AC-02
623	500 g	F1	YCW553-AC-02
423 323	200 g	F1	YCW523-AC-02
6202	5,000 g	F1	YCW653-AC-02
4202 3202 2202	2,000 g	F1	YCW623-AC-02
1202	1,000 g	F1	YCW613-AC-02
12201 10201	10,000 g	F2	YCW714-AC-02
8201 6201	5,000 g	F2	YCW654-AC-02
3201	2,000 g	F2	YCW624-AC-02
2201	2,000 g	F2	YCW624-AC-02

SARTORIUS

Visit eu.fishersci.com for more information

Distributed by Fisher Scientific. Contact us today:

Austria: fishersci.at **Belgium:** fishersci.be **Denmark:** fishersci.dk
Germany: fishersci.de **Ireland:** fishersci.ie **Italy:** fishersci.it
Finland: fishersci.fi **France:** fishersci.fr **Netherlands:** fishersci.nl
Norway: fishersci.no **Portugal:** fishersci.pt **Spain:** fishersci.es
Sweden: fishersci.se **Switzerland:** fishersci.ch **UK:** fishersci.co.uk

© 2025 Thermo Fisher Scientific Inc. All rights reserved.
Trademarks used are owned as indicated at fishersci.com/trademarks.

25452

